

NOTE: BREAK ALL CORENERS WITH 0.015" (0.38 MM) RADIUS UNLESS OTHERWISE NOTED. STANDARD TOLERANCES TO APPLY UNLESS OTHERWISE SPECIFIED.

CUSTOMER PART No.	CUSTOMER WOLVERINE OPEN SHAPE	WL.V DIE No. WH12110	REV No. 0
DESCRIPTION		QUOTE No. 24-1281-2	PROPOSAL No. H-19644

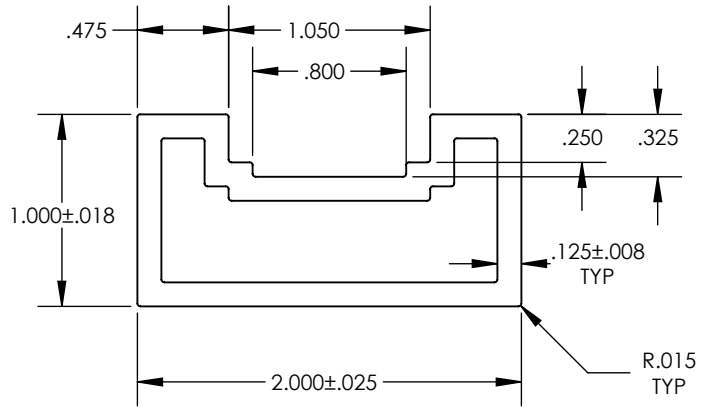

WALL THICKNESS .125 ± .008

DATE	REV	DESCRIPTION	BY
EST. AREA	.769	IN. ²	EST. AREA 496.128
EST. WT.	.900	LBS/FT.	EST. WT. 1.339
EST. PER.	12.145	IN.	EST. PER. 308.483
OUT PER.	6.573	IN.	OUT PER. 166.954
C.C.D.	2.226	IN.	C.C.D. 56.540
FACTOR 13	FINISH M/F	ALLOY & TEMP.	6063
CKD BY	SCALE 1:1	DWN BY	B.A. DATE 4/19/24

WOLVERINE

2100 MARKET STREET
DECATUR, AL 35816
800-633-3972

THIS DRAWING IS NOT NECESSARILY A COPY OF YOUR ORIGINAL. PLEASE APPROVE DIMENSIONS AND TOLERANCES INDICATED. WOLVERINE ASSUMES NO RESPONSIBILITY EITHER TECHNICAL OR LEGAL FOR HAVING THIS SHAPE MADE. THE CUSTOMER AGREES TO FULLY PROTECT WOLVERINE FROM CLAIMS OF OTHERS RESULTING FROM THIS SHAPE.

SIGNED: _____ DATE: _____
PRINT NAME: _____