

NOTE: BREAK ALL CORNERS WITH 0.015" (0.38 MM) RADIUS UNLESS OTHERWISE NOTED. STANDARD TOLERANCES TO APPLY UNLESS OTHERWISE SPECIFIED.

CUSTOMER PART No.	CUSTOMER <b>WOLVERINE STD</b>	WLV DIE No. <b>WH10207</b>	REV No. <b>0</b>
DESCRIPTION <b>1.00" O.D. x .250 THK TUBE</b>		QUOTE No. <b>18-1332-1</b>	PROPOSAL No. <b>H-10665</b>

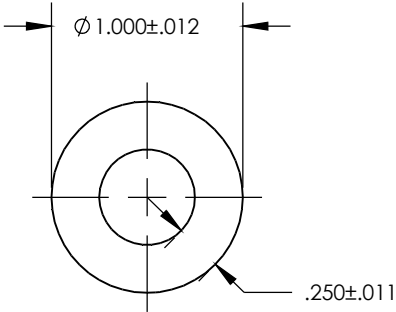

WALL THICKNESS .250 ± .011 EXCEPT AS SHOWN

DATE	REV	DESCRIPTION		BY	
EST. AREA	.589	IN. <sup>2</sup>	EST. AREA	379.999	MM. <sup>2</sup>
EST. WT.	.689	LBS/FT.	EST. WT.	1.025	KG/M
EST. PER.	4.712	IN.	EST. PER.	119.685	MM.
OUT PER.	3.142	IN.	OUT PER.	79.807	MM.
C.C.D.	1.000	IN.	C.C.D.	25.400	MM.
FACTOR 7	FINISH	M/F	ALLOY & TEMP.	6061	
CKD BY	SCALE	1:1	DWN BY	<b>B.A.</b>	DATE 9/18/18

**WOLVERINE**

2100 MARKET STREET  
DECATUR, AL 35816  
800-633-3972

THIS DRAWING IS NOT NECESSARILY A COPY OF YOUR ORIGINAL. PLEASE APPROVE DIMENSIONS AND TOLERANCES INDICATED. WOLVERINE ASSUMES NO RESPONSIBILITY EITHER TECHNICAL OR LEGAL FOR HAVING THIS SHAPE MADE. THE CUSTOMER AGREES TO FULLY PROTECT WOLVERINE FROM CLAIMS OF OTHERS RESULTING FROM THIS SHAPE.

SIGNED: \_\_\_\_\_ DATE: \_\_\_\_\_  
PRINT NAME: \_\_\_\_\_